

**Prepare Smart.**



Convenient, effective, and intelligent storm protection for your customers.

Approved by All Florida Building Codes.



*Our reputation expects it.™*



## Anchor Safe 50/50: An Engineering Breakthrough In Lightweight, Economical, Easy To Install Storm Panels

### Anchor Safe 50/50 Advantages:

- Unique panel profile allows lightweight .050 aluminum gauge construction
- Custom and standard sizes available
- Meets ALL Florida building code requirements, including:
  - Dade, Broward and Palm Beach counties
  - SSTD12-99 impact code
  - New Florida building code
- Nearly 20% lower cost than other storm panels
- SafetyEdge™ treated edge for safer handling
- Quick and easy installation and removal
- Three installation options and two anchor styles
- Impact tested to withstand 50 feet per second
- Special ribbed design – reinforces protection
- Stacks flat for space-saving storage
- Easy illustrated instructions available

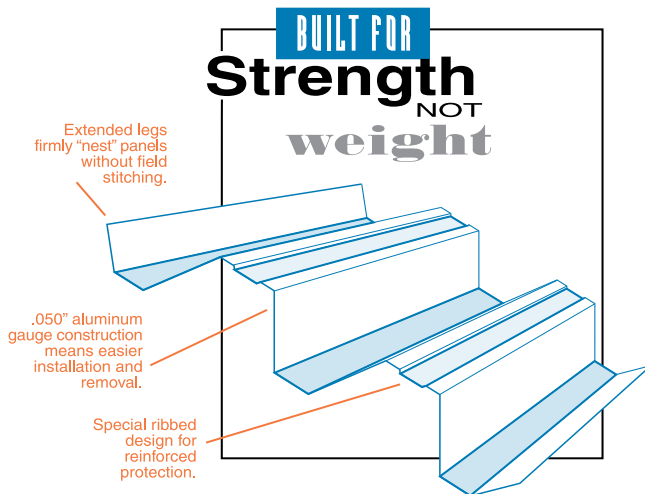

### Ask about Anchor Safe storm panels in these optional styles:

- 20, 24 and 28 gauge steel
- .063 and .024 nominal thickness aluminum
- Acrylic clear panels available